

# AIR / VACCUM VALVE (with THROTTLING DEVICE AND WATER DIFFUSER)

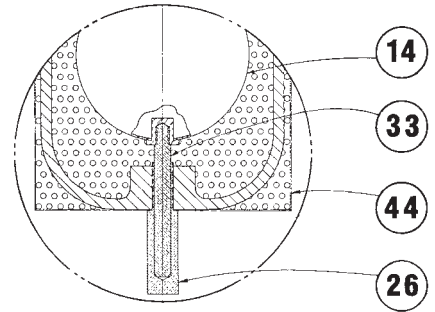
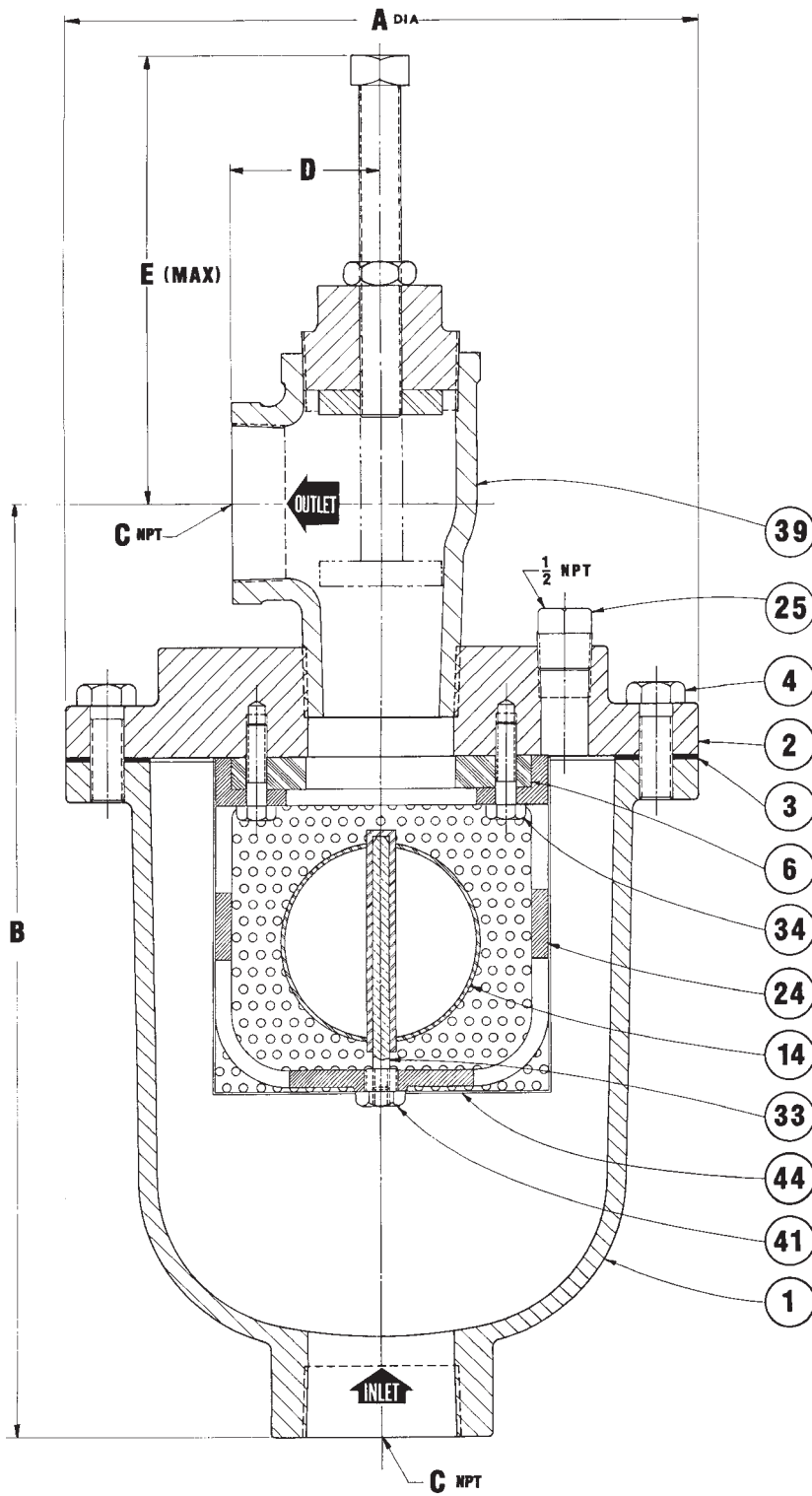

**3" 146TWD DETAIL**

DESIGN FOR: 125 LB., CLASS RATING  
200 PSI MAX. NON-SHOCK SERVICE.  
SPECIFY WORKING PRESSURE \_\_\_\_\_ PSI  
AVAILABLE WITH 125 LB. FLANGE INLET.  
ALSO AVAILABLE FOR 150 LB., 250 LB., 300 LB.,  
AND 600 LB. CLASS RATING.

DET	DESCRIPTION	MATERIAL
1	BODY	CAST IRON ASTM A126 GR. B
2	COVER	CAST IRON ASTM A126 GR. B
3	COVER GASKET	LEXIDE (non-asbestos)
4	COVER BOLT	STEEL ASTM A307 GR. B
6	SEAT	BUNA-N
14	FLOAT	STAINLESS STEEL ASTM A240 T304
24	BAFFLE <sup>1</sup>	DELFIN ASTM D4181
25	COVER PIPE PLUG <sup>2</sup>	MALLEABLE IRON
26	FLOAT BUSHING <sup>3</sup>	BRASS ASTM B16 C36000
33	FLOAT GUIDE	BRASS ASTM B16
34	BAFFLE SCREWS	STAINLESS STEEL 18-8
39	THROTTLING DEVICE	MALLEABLE IRON
41	BAFFLE PLUG <sup>4</sup>	BRASS ASTM B16
44	WATER DIFFUSER	BRASS (commercial)

1 STANDARD MATERIAL ON SIZE 3" IS CAST IRON ASTM A48 CL. 30.  
2 COVER PIPE PLUG IS NOT AVAILABLE ON SIZE 1 1/2".  
3 FLOAT STEM BUSHING IS REQUIRED ON SIZE 3".  
4 BAFFLE PLUG IS NOT REQUIRED ON SIZE 3".

SIZE	1/2"	1"	2"	3"
<b>MODEL No.</b>	<b>141TWD</b>	<b>142TWD</b>	<b>144TWD</b>	<b>146TWD</b>
<b>A</b>	5 1/8	7	9 1/2	9 1/2
<b>B</b>	8 3/8	10	15	17 1/4
<b>C</b>	1/2	1	2	3
<b>D</b>	1 1/8	1 1/2	2 1/4	3 3/8
<b>E</b>	2 3/4	3 3/8	7	10 1/4
APPROX. SHIPPING WT., LB.	12	23	54	80

CERTIFIED BY: \_\_\_\_\_

DATE: \_\_\_\_\_

DATE  
09-01-03



DRWG. NO.  
S-140TWD

SPECIFICATIONS OTHER SIDE

# APCO<sup>®</sup> SPECIFICATIONS

## SERIES 140TWD AIR / VACUUM VALVES

Air / Vacuum Valves shall be designed to allow large quantities of air to escape out the orifice when the vertical turbine pump starts and must close water tight when the liquid enters the valve. The Air / Vacuum Valves shall also permit large quantities of air to enter thru the orifice when the pump stops to break the vacuum and drain the pump suction. The discharge orifice shall be fitted with a throttling device, adjustable for restricting the discharge of air from the pump suction, if necessary, to minimize shock to the pump on pump starts.

The valve shall consist of a body, cover, float, seat and baffle. The baffle will be shrouded with a water diffuser, designed to protect the float from direct contact of the rushing air and water, to prevent the float from closing with shock. The seat shall be compression molded Buna-N, fastened to the valve cover without distortion, for tight shut-off and easy removal and replacement if necessary. The float shall be stainless steel, designed to withstand a minimum of 1000 psi (static). The float shall be center guided for positive shut-off into the seat.

The throttling device shall be malleable iron with a heavy steel adjusting screw and locknut for locking in place after correct settings are determined.

All materials of construction shall be certified in writing to conform to A.S.T.M. specifications as follows:

Body, cover	Cast iron	ASTM A126 Gr.B
Baffle [½", 1" & 2"]	Delrin	ASTM D4181
Baffle [3"]	Cast iron	ASTM A48 CL-30
Throttling Device	Cast iron	Commercial
<b>Float*</b>	Stainless steel	ASTM A240 T304
Seat	Buna-N	
Water diffuser	Brass	Commercial
Exterior paint	Universal Primer	FDA Approved for Potable Water Contact

**\*Float design may vary on certain sizes.**

Note: Other materials available.

Valve to be APCO Series 140TWD Air / Vacuum Valve with Throttling Device, per Bulletin 586, as manufactured by Valve & Primer Corporation, Schaumburg, Illinois, U.S.A.