

# AUTOMATIC CONTROL CHECK VALVE WITH MOTOR OPERATOR

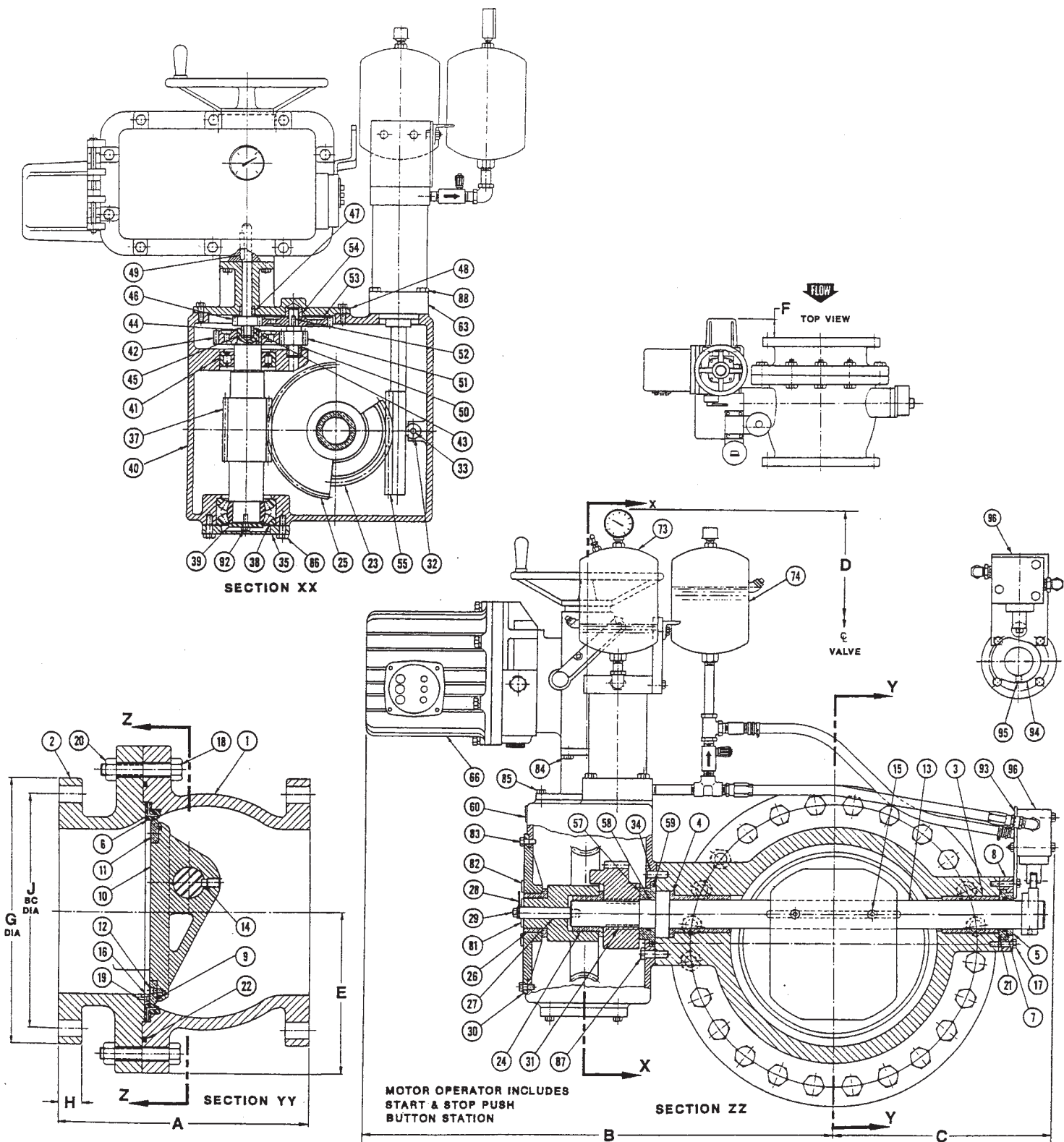

SPECIFY: VOLTAGE \_\_\_\_\_ PHASE \_\_\_\_\_ & CYCLES \_\_\_\_\_ FOR MOTOR, STARTER

DET	DESCRIPTION	MATERIAL	DET	DESCRIPTION	MATERIAL	DET	DESCRIPTION	MATERIAL
1	BODY PIVOT HALF	CAST IRON ASTM A 126 CL.B	26	WORMWHEEL EXTERNAL BUSHING	BRONZE ASTM B584	52	1st REDUCTION SPUR GEAR KEY	STEEL AISI 1018
2	VALVE BODY HALF	CAST IRON ASTM A 126 CL.B	27	INDICATOR SHAFT	BRASS B 16	53	1st REDUCTION SPUR GEAR	DUCTILE IRON ASTM A536
3	STRAIGHT PIVOT BUSHING	BRONZE ASTM B584	28	DISC POSITION INDICATOR	BRASS B 16	54	PINION SHAFT TOP BUSHING	BRONZE ASTM B584
4	FLANGED PIVOT BUSHING	BRONZE ASTM B584	29	DISC POSITION INDICATOR SET SCREW	ALLOY STEEL H.T.	55	RACK	STEEL AISI 1018
5	PIVOT SHAFT SEAL RETAINER	BRONZE ASTM B584	30	WORMWHEEL COVER	DUCTILE IRON ASTM A536	57	PIVOT SHAFT THRUST BEARING	BRONZE ASTM B584
6	BODY SEAT RING W/REINFORCING RING	BUNA-N/STEEL	31	GEAR SEGMENT KEY	STEEL AISI 1018	58	PIVOT SHAFT SEAL	BUNA-N
7	PIVOT SHAFT END SEAL	BUNA-N	32	RACK ROLLER	STAINLESS STEEL ASTM 582	59	PIVOT SHAFT THRUST BEARING SEAL	BUNA-N
8	PIVOT SHAFT COVER	CAST IRON ASTM A48 CL.30	33	RACK ROLLER SHAFT	ALLOY STEEL H.T.	60	NAME PLATE	ALUMINUM
9	DISC RING SEAL	BUNA-N	34	GEAR HOUSING POLARIZING PIN	ALLOY STEEL H.T.	63	DASHPOT CYLINDER	STEEL COMMERCIAL
10	DISC	DUCTILE IRON ASTM A536	35	WORMSHAFT COVER	STEEL AISI 1018	66	MOTOR OPERATOR	COMMERCIAL
11	DISC RING	BRONZE ASTM B584	37	WORMSHAFT	STEEL AISI 1045	73	HYDRO-PNEUMATIC ACCUMULATOR	H.R. STEEL COMM'L QUALITY
12	DISC RING RETAINING SCREW	STAINLESS STEEL 18-8	38	WORMSHAFT THRUST BEARING	STEEL COMMERCIAL	74	OIL RESERVOIR	H.R. STEEL COMM'L QUALITY
13	PIVOT SHAFT	STAINLESS STEEL 17-4PH	39	THRUST BEARING LOCK WASHER	STEEL AISI 1018	81	CONTROL POSITION INDICATOR	BRASS B16
14	PIVOT SHAFT KEY	STAINLESS STEEL T416	40	GEAR HOUSING	DUCTILE IRON ASTM A536	82	DIAL	BRASS B16
15	PIVOT SHAFT SET SCREW	STAINLESS STEEL 18-8	41	WORMSHAFT RADIAL BEARING	STEEL COMMERCIAL	83	WORMWHEEL COVER BOLT	STEEL ASTM A307 GR.B
16	DISC STOP	STAINLESS STEEL T304	42	2nd REDUCTION SPUR GEAR	DUCTILE IRON ASTM A536	84	OPERATOR MOUNTING BOLT	STEEL ASTM A307 GR.B
17	PIVOT SHAFT COVER BOLT	STEEL ASTM A307 GR.B	43	2nd REDUCTION SPUR GEAR KEY	STEEL AISI 1018	85	GEAR HOUSING TOP COVER BOLT	STEEL ASTM A307 GR.B
18	FLANGE BOLT	STEEL ASTM A307 GR.B	44	SPUR GEAR RETAINING RING	STAINLESS STEEL COMM'L	86	WORMSHAFT COVER BOLT	STEEL ASTM A307 GR.B
19	DISC STOP RETAINING SCREW	STAINLESS STEEL 18-8	45	DRIVE PINION SHAFT BOTTOM BUSHING	BRONZE ASTM B584	87	GEAR HOUSING RETAINING BOLT	STEEL ASTM A307 GR.B
20	FLANGE NUT	STEEL ASTM 563	46	DRIVE PINION SHAFT	STEEL AISI 1045	88	WORMSHAFT RETAINING BOLT	STEEL ASTM A307 GR.B
21	PIVOT SHAFT COVER SEAL	BUNA-N	47	DRIVE PINION SHAFT TOP BUSHING	BRONZE ASTM B584	92	THRUST BEARING LOCK SCREW	STEEL AISI 1018
22	FLANGE SEAL	BUNA-N	48	TOP COVER PLATE	DUCTILE IRON ASTM A536	93	TIMING VALVE BRACKET	STEEL AISI 1018
23	GEAR SEGMENT	STEEL ASTM A148	49	OPERATOR KEY	STEEL AISI 1018	94	TIMING VALVE CAM	CAST IRON ASTM A48 CL.30
24	WORMWHEEL INTERNAL BUSHING	BRONZE ASTM B584	50	PINION SHAFT BOTTOM BUSHING	BRONZE ASTM B584	95	CAM SET SCREW	ALLOY STEEL H.T.
25	WORMWHEEL	DUCTILE IRON ASTM A536	51	PINION SHAFT	STEEL AISI 1045	98	TIMING VALVE	ALUMINUM ALLOY 2024-T351

VALVE SIZE	125 LB. & 250 LB. CLASSES						125 LB. CLASS				250 LB. CLASS					
	A	B	C	D	E	F	G	H	J	DIA of HOLES	NO. of HOLES	G	H	J	DIA of HOLES	NO. of HOLES
6"	15	27 1/2	10	23 1/4	8 3/4	9 3/4	11	1	9 1/2	7/8	8	12 1/2	1 7/16	10 5/8	7/8	12
8"	16 1/2	27 3/4	10 1/4	23 1/2	9 1/4	9	13 1/2	1 1/8	11 3/4	7/8	8	15	1 5/8	13	1	12
10"	18 1/2	31 1/2	12 1/8	24 3/4	11 1/4	8 3/4	16	1 3/16	14 1/4	1	12	17 1/2	1 7/8	15 1/4	1 1/8	16
12"	20	33 1/4	13 3/4	25	12 3/4	8	19	1 1/4	17	1	12	20 1/2	2	17 3/4	1 1/4	16
14"	22	37 1/4	15 1/4	25 1/4	14	6 1/2	21	1 3/8	18 3/8	1 1/8	12	23	2 1/8	20 1/4	1 1/4	20
16"	24	37 1/4	16 1/2	37 1/2	15 1/2	8 3/4	23 1/2	1 7/16	21 1/4	1 1/8	16	25 1/2	2 1/4	22 1/2	1 3/8	20
18"	25 1/2	40	19 1/2	37 3/4	18 1/4	7	25	1 9/16	22 3/4	1 1/4	16	28	2 3/8	24 3/4	1 3/8	24
20"	27	40 1/4	19 3/4	38	18 1/2	6 1/2	27 1/2	1 11/16	25	1 1/4	20	30 1/2	2 1/2	27	1 3/8	24
24"	32 3/4	41 1/2	25	50	22 1/2	6	32	1 7/8	29 1/2	1 3/8	20	36	2 3/4	32	1 5/8	24
30"	38	42	26 1/4	50 1/4	25	5	38 3/4	2 1/8	36	1 3/8	28	43	3	39 1/4	2	28
36"	42	45	34	50 3/4	29	4	46	2 3/8	42 3/4	1 5/8	32	50	3 3/8	46	2 1/4	32
42"	48	-	39	-	34	-	53	2 5/8	49 1/2	1 5/8	36	57	3 11/16	52 3/4	2 1/4	36
48"	54	-	43	-	38	-	59 1/2	2 3/4	56	1 5/8	44	65	4	60 3/4	2 1/4	40

DATE  
09-01-03



DRWG. NO.  
S-8000

DRWG. NO.  
S-8000

SPECIFICATIONS OTHER SIDE

# APCO<sup>®</sup> SPECIFICATIONS

## SERIES 8000 AUTOMATIC CONTROL CHECK VALVE (ACCV) WITH MOTOR OPERATOR

The (ACCV) Pump Discharge Control Valve shall have a single disc "offset" pivoted above centerline of the valve partially balanced capable of closing with minimal backflow for bubble tight shut-off no slam closure upon power failure - without any auxiliary power source supply or solenoid valves or oil accumulators. The offset pivot disc shall provide minimal seating and un-seating torques to prevent seat wear. The disc seat ring shall be bolted on - not welded for replaceability.

The ACCV shall be electrically controlled for normal pump start/stop combined with a gear arrangement capable to open against down stream pressure to permit draining line, when desired.

The ACCV shall have full flow area, designed to operate as a positive shutoff throttling and check valve. The ACCV shall be controlled through a lost motion type of gear arrangement mounted on the side of the valve, totally enclosed in a lubricated gear box. The ACCV operating as a check or throttling valve shall operate hydraulically thru an oil dashpot connected to the lost motion gearing. The open/close speeds, when used as a throttle or flow sensitive check valve, shall be independently adjustable to allow the valve to open or close at a rate compatible with the installation, without slamming and minimal pressure rise.

The ACCV must be fail safe during any electrical power failure and the disc shall close hydraulically, energized only by flow reversal in the line. Time of disc closure shall be adjustable from 3 seconds to 5 minutes, by means of a cam operated (dump type) timing valve, permitting instant 1st stage closure to any degree and a hydraulic dashpot for then second and third stage toward final closure.

The ACCV body shall be two (2) piece design, bolted together in a manner to capture the seat and be enlarged Globe Style thru the disc section to create a 100% flow thru area to minimize head loss. The body shall have a built-in stop to positively prevent the disc from over-traveling the shutoff position. The body seat and disc ring must be hand replaceable in the field, by the customer, without need for machining or need to remove complete valve from the line. The seat material shall be precision molded Buna-N, reinforced with heavy steel insert and be interchangeable.

The valve shaft shall be one piece stainless steel 17-4PH material, extending completely through the valve disc and gear box (not stub shafts).

Valve exterior to be painted with Universal Primer Paint as accepted by the FDA for use in contact with potable water for resistance to corrosion.

Valve to be APCO Series 8000 Automatic Control Check. Valve with motor operator, as manufactured by VALVE & PRIMER CORPORATION, Schaumburg, Illinois, U.S.A.