



SURGE RELIEF VALVES *for Sewage or Water*

SERIES 3000
Angle Surge Relief Valve
2" to 8"



SERIES 6500
Globe Surge Relief Valve
2" to 12"

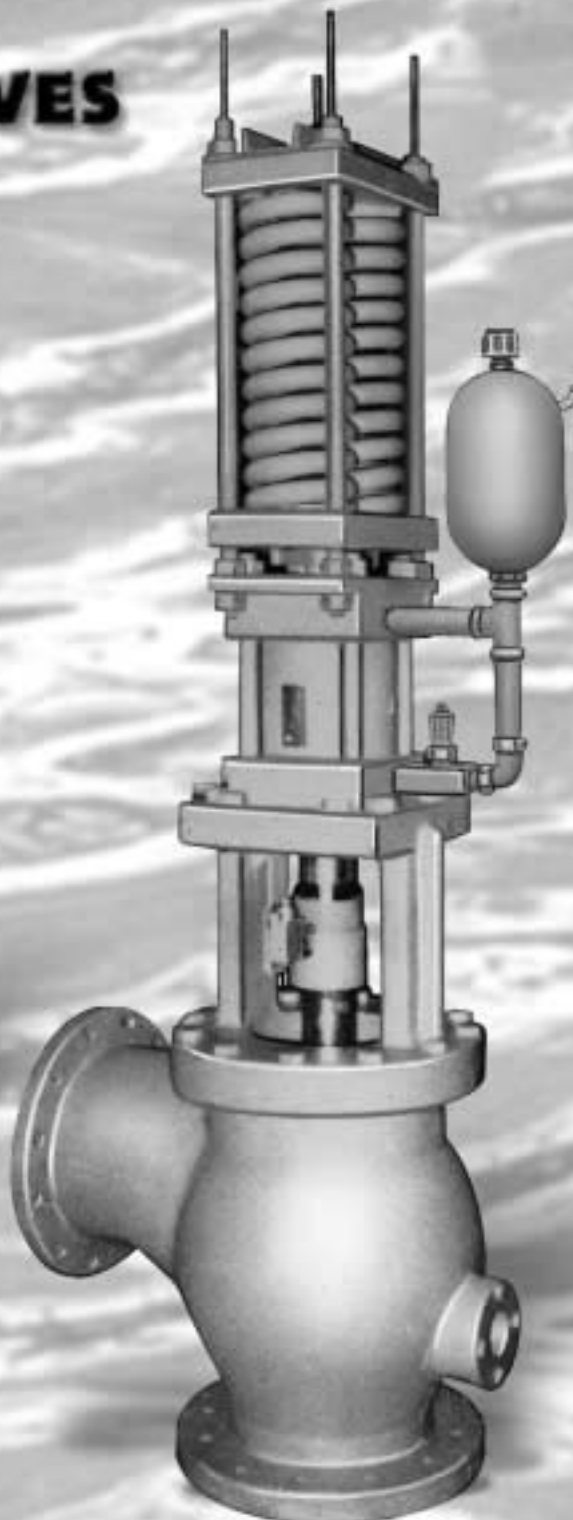
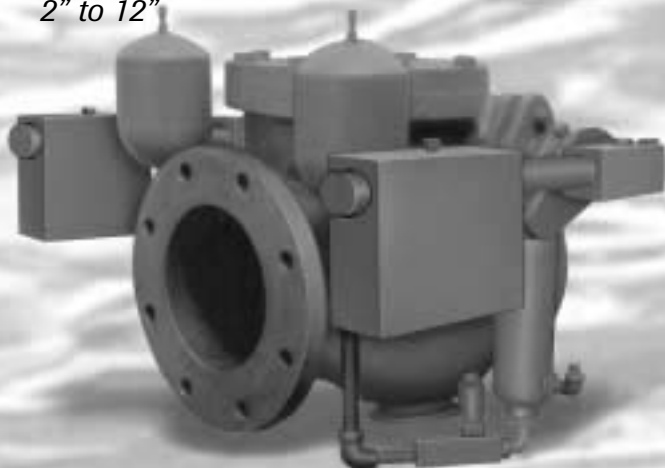

SERIES 3000
Angle Surge Relief Valve
10" and larger

B U L L E T I N
3 0 0 0

SURGE RELIEF VALVES
for Sewage and Water

SURGE RELIEF VALVES

VALVE & PRIMER CORPORATION

1420 S. WRIGHT BLVD. • SCHAUMBURG, IL 60193-4599
847.524.9000 • FAX:847.524.9007 • 800.323.6969
website: www.apcovalves.com • e-mail: factory@apcovalves.com

Put an end to unpredictable pressure surges . . .

. . . use APCO Surge Relief Valves for raw sewage or water pipeline protection.

PRESSURE SURGE CONTROL (COMBINED WITH) CORRECT CHECK OR CONTROL VALVE AND AIR VALVE SELECTION

In recent years Pumping Systems have become more complex than ever before. As a result of this, Design Engineers must resort to detailed water hammer and pressure surge analysis to insure the system will not be damaged due to negative or positive pressure surges. Water Hammer is caused by sudden changes in flow (ie; the rapid opening or closing of a main line valve or the starting and stopping of a pump can create this sudden flow change).

One method most often used by Engineers to prevent damage to the system is to spill some of the media from the system, thereby dissipating the pressure surges.

Typically, for this type solution, APCO can provide various controlled closing check valves, hydraulic Air Valves or two spilling type Surge Relief Valves, Models 3000 and 6500.

Where conventional check valve closure is determined to be undesirable, Series 800 or Series 6100 with a hydraulic dashpot, Series 8000 or APCO Willamette Ball and Cone valves with appropriate controls all offer excellent surge control. All can have fail-safe hydraulic controls to protect the pipeline even during power failure. Additionally, the 8000 Series, as well as the Ball and Cone valve, can have electric motor control for total valve control from a remote station. Where conventional Air Valve closure is determined to be undesirable, the Series 7000 Hydraulic Air Valve provides excellent surge control.

Control type Check valves, or Ball and Cone valves combined with controlled air valves, with either spill type valve Series 3000 or 6500 surge relief valves, will provide water hammer control for your Pumping System.

The more elaborate and complex a Water Hammer Control System Design is, the more need for rigid and regular operator training and equipment maintenance. APCO Valves are easy to operate and require minimal operator training or maintenance.

For practical and theoretical knowledge about pipeline surge protection contact our Engineering Department. We can assist with your pipeline design and selection of: Conventional Check Valves, Pump Control Valves, Conventional or Controlled Air Valves and spill type Surge Relief Valves.

Don't invest in an expensive Water Hammer Control System for surge pressure protection until you have examined the feasibility of trying APCO Surge Control Valves together with APCO Control Check Valves.

HOW BOTH STYLES WORK

Both styles of APCO Surge Relief Valves operate in like manner, opening when the system pressure exceeds the set shut-off pressure of the valve disc 10. As the disc opens, the surge pressure rise that caused it to open is spilled and dissipated through the open valve. When system pressure drops below the set shut-off pressure, the valve disc 10 slowly closes against the oil contained in the cushion chamber 20 or 58 and cylinder 33. Disc closing time is adjustable by regulating control valves 59 or 35. Both style valves are designed with a smooth flow and minimal obstruction to flow for efficient surge relief. The only part in contact with flow is the disc 10, thereby eliminating fouling problems of the internal parts. The Angle Surge Relief Valve Series 3000 has a much higher pressure relief rating than the Globe Surge Relief Valve Series 6500 because of the direct acting piston design and wide range of spring selections.

SURGE RELIEF CAPACITY				
VALVE SIZE	TOTAL MAIN LINE G.P.M. FLOW	MAXIMUM RELIEF PRESSURE P.S.I.		APPROXIMATE OPEN SEAT AREA THROUGH VALVE SQ. IN.
		*3000	6500	
2"	UP TO 600	175	150	3
2½"	UP TO 800	N/A	125	4.5
3"	UP TO 1000	175	100	7
4"	1000 TO 2250	175	75	13
6"	2250 TO 4700	175	35	26
8"	4700 TO 8250	150	18	50
10"	8250 TO 15000	100	12	79
12"	15000 TO 20000	100	7.5	113
14"	20000 TO 30000	100	—	154
16"	30000 TO 36000	75	—	201
18"	36000 TO 45000	75	—	255
20"	45000 TO 55000	50	—	314

N/A = NOT AVAILABLE
* HIGHER RELIEF PRESSURES AVAILABLE

NOTE: For unusual applications or sizing information contact our Engineering Department.

SERIES 6500 Globe Surge Relief Valves

PRESSURE SETTING

The Globe Surge Relief Valve Series 6500 is easily set by moving weights **29** along the arms **44**. Moving the weights toward the open end of the arms increases the pressure relief point. Moving the weights toward closed end of the arms decreases the pressure relief point. Lock weights in place by tightening cap screws with a wrench.

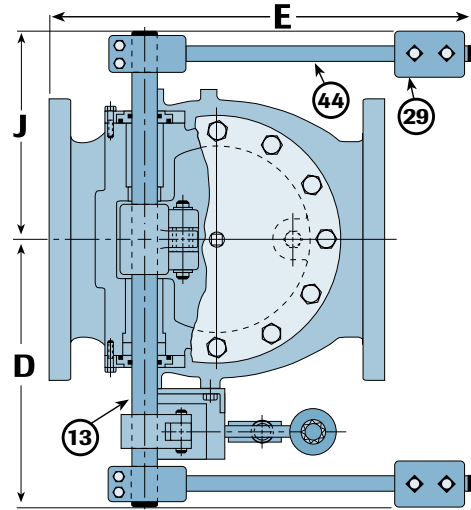

1	Body	Cast Iron ASTM A126 GR. B
2	Cover	Cast Iron ASTM A126 GR. B
6	Disc Seat	Buna-N
9	Disc Arm	Ductile Iron ASTM A536 or Steel
10	Disc	Cast Iron ASTM A126 GR. B
13	Pivot Shaft	Stainless Steel ASTM A582 T303
20	Hydraulic Cylinder	Steel
29	Counter Weight	Cast Iron ASTM A126 GR. B
31	Seat Retaining Ring	Aluminum Bronze
44	Counter Weight Arm	Steel AISI C-1018
58	Oil Reservoir	Steel
59	Control Valve	Brass

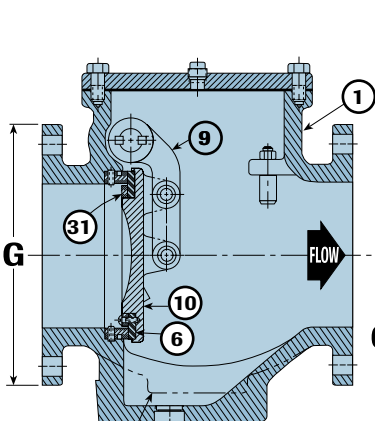

FOR SIZES 2" TO 8"
FLUSH AND DRAIN OPENING
SPECIFY IF OTHER THAN HORIZONTAL INSTALLATION.
ANGLE OF WEIGHT LEVER AND OIL RESERVOIR MUST BE CHANGED.

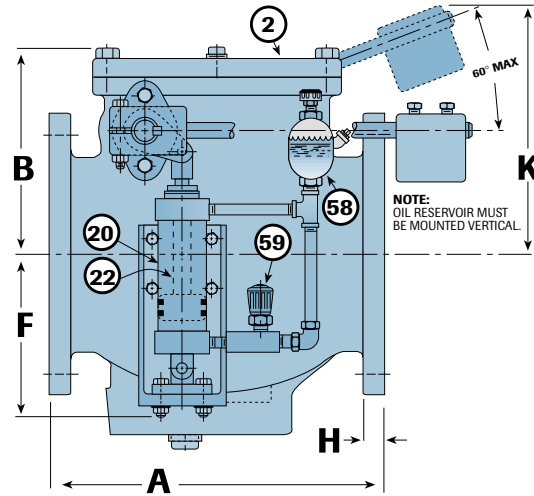

VALVE SIZE	2"	2 1/2"	3"	4"	6"	8"	10"	12"
MODEL No.	6502	6502½	6503	6504	6506	6508	6510	6512
A	9	12	12	13	17½	18	23	28
B	5%	6%	7	7%	10	12	14½	16
C	3½	4	4½	5	6½	7½	14	16
D	16	17	17	16	21	20	22	23½
E	26	27	27	42	48	56	63	72
F	10%	10%	10	10%	14	12½	16	16
G	6	7	7½	9	11	13½	16	19
H	¾	1 1/8	¾	1 1/8	1	1 1/8	1 1/8	1 1/8
J	5	5%	12½	13	17	16	17	20½
FLANGE HOLES	No.	4	4	4	8	8	12	12
	DIA.	¾	¾	¾	¾	¾	1	1
	B.C.D.	4%	5%	6	7%	9½	11%	14%
K	25	27	28	39	43	53	59	66
MAXIMUM VALVE OPENING PRESSURE (PSI)	150	125	100	75	35	18	12	7.5

* Consult factory when opening pressure exceeds those listed.
NOTE: Sizes 2" & 2 1/2" have only one counterweight. (Right side)

OPERATION

When system pressure rises above the set pressure on the valve, disc **10** immediately free opens, rotating the shaft, lifting the weights while simultaneously raising piston **22**, allowing oil to flow from the oil reservoir **58**, through the control valve **59**, into the hydraulic cylinder. As pressure drops below the surge valve setting, disc **10** starts to close, pushing piston **22** downward forcing oil out of the hydraulic cylinder **20**. Control valve **59** regulates the flow of oil being displaced, thereby controlling the closing speed. (Restrict the control valve for slower closing; open control valve for faster closing.) We recommend slow closing speed while testing and gradually increased closing speed to suit your system.

FIELD INSTALLATION

All Surge Relief Valves are delivered to the jobsite factory adjusted and ready for installation. The valves need only to be bolted to the pipe flange connection and the Surge Relief Valve is operational. APCO tests all Surge Relief Valves at the factory for quick opening at the desired relief pressure specified. However, final field adjustments to weights and springs may be required to suit actual field conditions. Always install the Surge Relief Valve with the replaceable resilient seat of the disc facing the system pressure. The valve outlet must be piped to discharge into the wet well or into a spillway (see illustration). Angle Surge Relief Valves may be installed vertically or horizontally, discharge downwards, thus eliminating cost for an elbow fitting. Oil reservoir must be mounted vertically, regardless of valve installation.

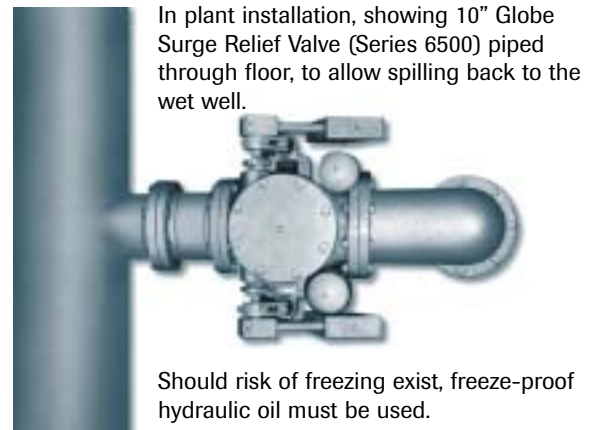

SERIES 3000

Angle Surge Relief Valves

HIGHER PRESSURE CLASSES AVAILABLE

The Angle Surge Relief Valve Series 3000 is set by tightening or loosening the bolt or nuts 22. Greater tension on the helical spring increases the pressure relief point and less tension decreases the pressure relief point. Lock nuts hold the setting in place.

NOTE:
SPRING ENCLOSURES AND OTHER SPRING CONFIGURATIONS ARE AVAILABLE. CONTACT FACTORY.

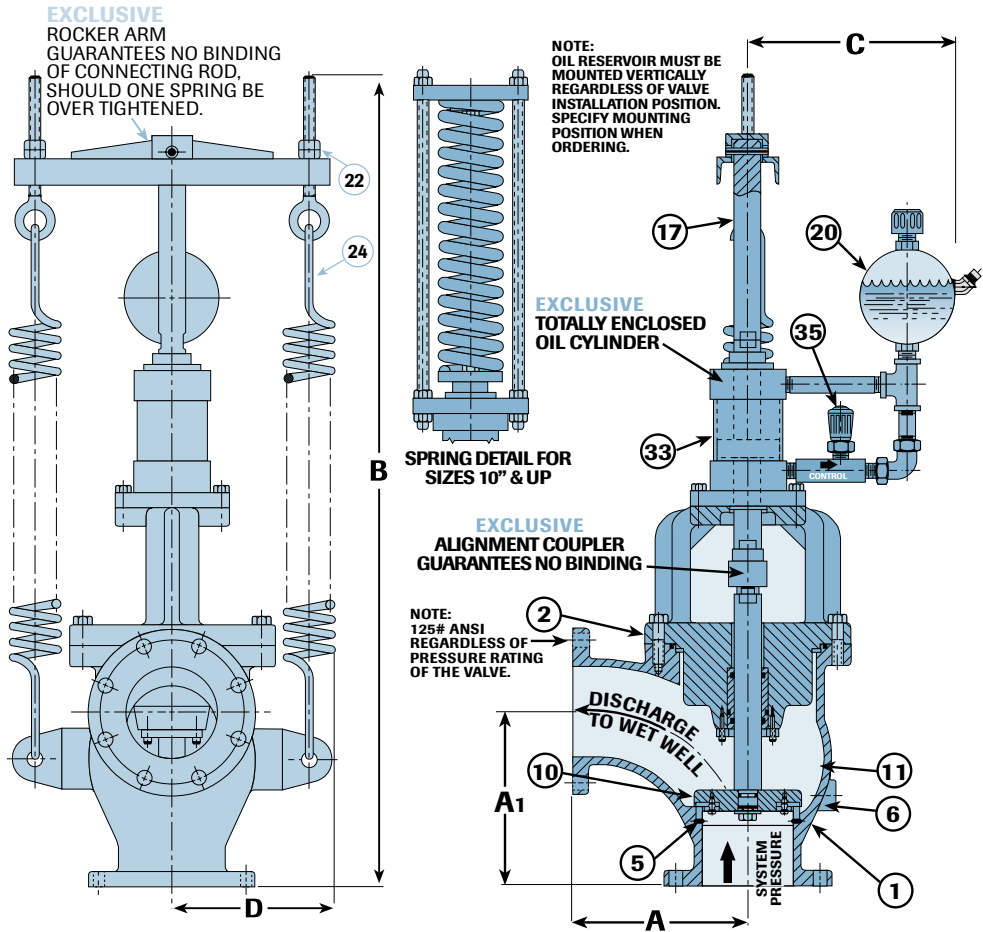

OPERATION

Helical springs 24 hold the disc 10 closed. When system pressure rises above the set pressure on the springs, disc 10 moves freely open, raising the piston inside cylinder 33, allowing oil from reservoir 20 to enter below the piston. When disc 10 closes, it does so at a slow controlled rate regulated by the control valve 35. As the system pressure drops below the surge valve setting, disc 10 starts controlled closing, pushing the cylinder piston downward, forcing oil from the bottom of the cylinder chamber 33. Control valve 35 regulates the flow of oil being displaced, thereby controlling the closing speed. (Restrict the control valve for slower closing, open the control valve for faster closing.) We recommend slow closing speed while testing, and gradually increased closing speed to suit your system.

STANDARD 125# CLASS ANSI FLANGES							ESTIMATED SHIPPING WEIGHT
MODEL NO.	VALVE SIZE	A	A ¹	B	C	D	
3002	2"	6%	6%	37%	7	7%	225lbs
3003	3"	9	9	52%	7	6%	300lbs
3004	4"	10	10	54%	8	9	400lbs
3006	6"	11½	11½	60%	8	11	500lbs
3008	8"	14	14	69%	8	13	550lbs
3010	10"	16½	16½	84	11	11	650lbs
3012	12"	19	19	95	13	13	1100lbs
3014	14"	21½	21½	102	16	16	1600lbs
3016	16"	24	24	109	23	16½	1900lbs
3018	18"	24%	20	112%	24	20%	2600lbs
3020	20"	25%	20	138	30	21½	3200lbs

1	BODY	C.I. ASTM A126 GR. B
2	COVER/SPACER	D.I. ASTM A536
5	BODY SEAT RING	AL. BR, ASTM B-148-9C
6	DISC SEAT	BUNA-N
10	DISC	STEEL ASTM A36
11	STEM	S.S. TYPE 303
17	CONNECTING ROD	STEEL COLD FINISH 1042
20	OIL RESERVOIR	S.S. TYPE 304
22	EYE BOLT NUT	STEEL COMM'L
24	SPRING	STEEL
33	DASHPOT CYLINDER	STEEL COMM'L
35	FLOW CONTROL VALVE	BRASS COMM'L

APCO SURGE RELIEF VALVE SIZING

1. What is maximum allowable pressure in line, P_L in pounds per square inch?
2. What is maximum velocity, V_L in feet per second? For gravity line flow: Find maximum flow rate-determine velocity. For pressure lines: Maximum velocity is the velocity water would be pumped through the line at maximum flow.
3. Divide V_L by P_L .
4. Enter graph with V_L/P_L . Find intersection with curve representing your pipeline diameter.
5. From the intersection of V_L/P_L and line size curve, go horizontally over to Surge Relief Valve size. For non-standard sizes, use next larger size valve, or use a combination of smaller valves equal in area to the size from the graph.

EXAMPLE:

Data:

12" Line, 3000 gpm, Maximum System Pressure- 185 psi.

Sizing Steps:

1. Determine Line Velocity, in this case 8.5 fps.
2. Divide Velocity by Relief Pressure
3. Find this on bottom scale - follow vertically to intersection with curve for 12 inch line.
4. Go horizontally to point on vertical scale - this gives valve size: In this case - a 4 inch Valve. Model 3004.

NOTE:

This sizing chart is based on present Engineering practice for use on pipelines whose operation conditions are not considered unusual. Due to the many unforeseen hydraulic conditions associated with pipeline operation, no guarantees are intended or otherwise implied.

SIZING GRAPH

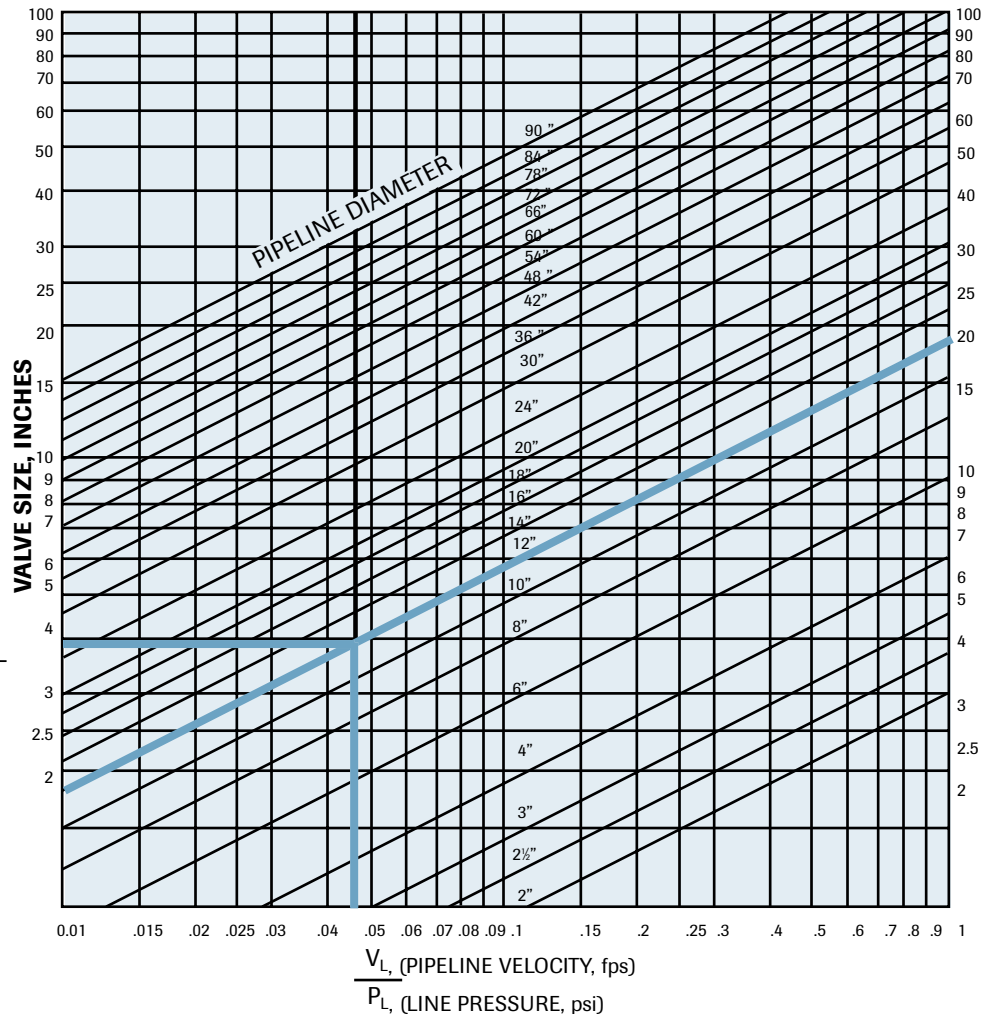

(FOR WATER HAMMER DUE TO INSTANTANEOUS CHANGES IN WATER VELOCITY)

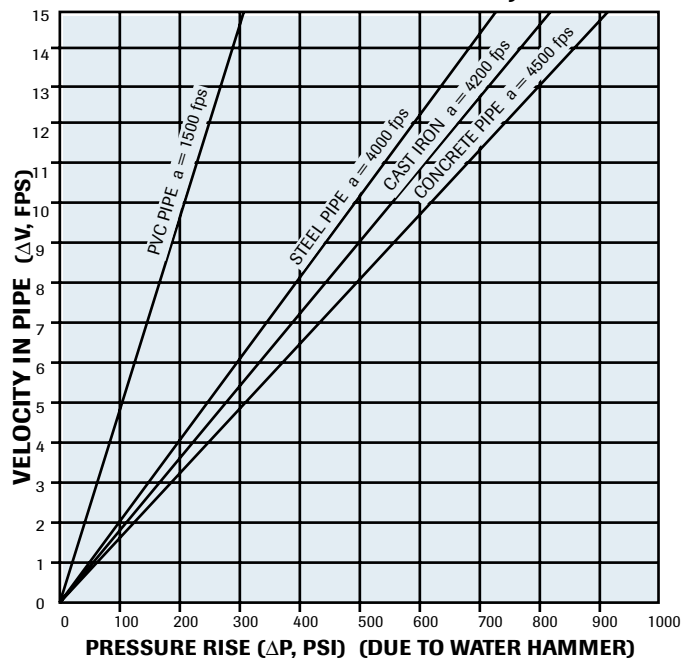

$$\Delta H = -a_g \Delta V$$

INCREMENTAL PRESSURE VS. FLOW VELOCITY

SERIES 3000 ANGLE SURGE RELIEF VALVES

The Angle Surge Relief Valve shall be heavily constructed cast iron body and ductile iron cover, to withstand severe shock conditions. The body shape shall be 90° angle pattern to permit side or downward discharge.

The cover shall provide an air gap between the surge valve and the hydraulic cylinder. The valve stem shall be connected to the hydraulic cylinder by means of a SELF-ALIGNING UNIVERSAL CONNECTOR to insure smooth positive opening, without binding, during opening of the valve.

The hydraulic cylinder shall be removable from the valve without dismantling or removing the valve from the line. Closing speed shall be externally adjustable by means of a coded micrometer control valve.

The valve disc shall be normally closed against the system operating pressure by means of a spring or springs. When the system pressure exceeds the normal operating pressure by 10%, the Angle Surge Relief Valve shall open immediately to relieve the pressure surge and close slowly as the system pressure returns back to normal.

The hydraulic cylinder shall be capped on both ends (totally enclosed) to prevent dirt or dust from fouling up the cylinder operation. It shall be fitted with an atmospheric oil reservoir.

The relief pressure shall be set at the factory, but additional adjustments can be made in the field by increasing or decreasing the tension on the externally adjustable springs. Specify Pressure Class _____ and relief pressure setting _____.

Valve exterior to be painted with Universal Metal Primer as accepted by the FDA for use in contact with Potable Water.

All materials of construction shall be certified in writing to A.S.T.M. specifications as follows:

Body	Cast Iron	ASTM A126 Gr.B
Body Seat Ring	Aluminum Bronze	ASTM B148
Cover	Ductile Iron	ASTM A536
Disc Seat	Buna-N	
Disc	Steel	ASTM A36
Heavy duty hydraulic Cylinder	Steel	Commercial

Valve to be APCO Series 3000 Angle Surge Relief Valve, as manufactured by Valve & Primer Corporation, Schaumburg, Illinois, U.S.A.

SERIES 6500 GLOBE SURGE RELIEF VALVES

The Globe Surge Relief Valve shall be heavily constructed cast iron valve body with integral end flanges and a full unobstructed flow through area.

The disc shall be cast iron having a replaceable resilient Buna-N seat for tight shut-off. The Pivot shaft shall be Type 303 stainless steel and be a single unit (not stubs), extending through the valve body with a weight and lever mounted on one or both ends.

The Globe Surge Relief Valve shall be adjusted at the factory to hold closed against the normal operating system pressure. When the system pressure exceeds this setting, the Globe Surge Relief Valve shall open immediately to relieve the pressure rise, but close slowly at an adjustable rate as the system pressure returns to normal.

A heavy duty oil dashpot system shall be externally mounted on the valve to control the rate of closure to positively prevent any slam. The oil shall be stored in a stainless steel reservoir maintaining a constant head on the dashpot to immediately fill the dashpot when the valve opens, insuring non-slam closure. The closing rate shall be externally and infinitely adjustable through a coded flow control valve with a locking device. Specify Pressure Class _____ and relief pressure setting _____.

Valve exterior to be painted with Universal Metal Primer as accepted by the FDA for use in contact with Potable Water.

All materials of construction shall be certified in writing to A.S.T.M. specifications as follows:

Body	Cast iron	ASTM A126, Gr.B
Cover	Cast iron	ASTM A126, Gr.B
Disc seat	Buna-N	
Disc	Cast iron	ASTM A126, Gr.B
Pivot shaft	Stainless steel	ASTM A582 T303

Valve to be APCO Series 6500 Globe Surge Relief Valve, as manufactured by Valve & Primer Corporation, Schaumburg, Illinois, U.S.A.